

SmartLog Pro® 2 Installation, Operation, and Maintenance



Made in the
United States of America



Figure 1. EMIT 50180 SmartLog Pro® 2

Description

The EMIT SmartLog Pro® 2 verifies the functionality of an operator's wrist strap and footwear, logs the test results, and controls access to an ESD Protected Area.

The default test limits are set to:

Wrist Strap: 750 kilohms to 10 megohms

Footwear: 750 kilohms to 35 megohms

All operator test activity is logged into the SmartLog Pro® Manager Web App to meet the ANSI/ESD S20.20 requirements for an ESD Control Plan. The app is installed onto one server and accessed via a web browser. Each log entry includes operator identification, test results, resistance measurements, time, temperature, and humidity. Operator identification and access control is initiated with the embedded [rf IDEAS WAVE ID® Plus](#) proximity card reader or touchscreen keypad. Access control to an ESD Protected Area can be further enforced by using the relay terminal and connecting to an electronic door lock or turnstile to grant access only to those who have passed their pre-defined ESD tests and are authorized to be in the ESD Protected Area.

The seven-inch color touchscreen on the SmartLog Pro® 2 provides an intuitive user interface for easy test operation and a clear indication of test results. The operator average test time is 2 seconds. Internal flash memory allows operators to continue using the tester even if network failure were to occur. All test transactions download to the database once the network connection is restored.

The SmartLog Pro® 2 is calibrated to NIST traceable standards.



SmartLog Pro® Manager Web App

SmartLog Pro® Manager automates the collection of ESD personnel grounding tests and maintains records for a Compliance Verification Plan as required by ANSI/ESD S20.20. It includes functions for tracking employee leave time, shift and department assignments, and ESD training accreditation. SmartLog Pro® Manager generates automated reports that may be e-mailed to track short term and long term corrective actions. Test limits and test parameters (wrist strap only, footwear only, wrist strap and footwear, etc.) may be customized with the web app to meet special requirements.

SmartLog Pro® Manager is only compatible with the SmartLog Pro® SE and SmartLog Pro® 2 models. It is required for every SmartLog Pro® 2 system installation. Contact EMIT Customer Service to schedule an installation session.

See technical bulletin [TB-6605](#) for more information.

ESD Association Information

For more information on ESD Control Plan requirements, please visit the ESD Association website at [esda.org](#).

Contents

3	System Overview
4	Items and Accessories
4	Packaging
5	Features and Components
6	Installation
6	Configuring the Proximity Reader
7	Cloning the Proximity Reader
7	Hardware Setup
8	10 mm Wrist Cord Adapter
9	Relay Terminal
9	Wi-Fi Setup
10	Language Selection
10	Sync Internet Time
11	Test Limit Configuration
12	Operation
13	Maintenance
13	Replacing the Dual-Wire Wrist Strap Jack
14	Calibration
14	Specifications
14	Limited Warranty

System Overview

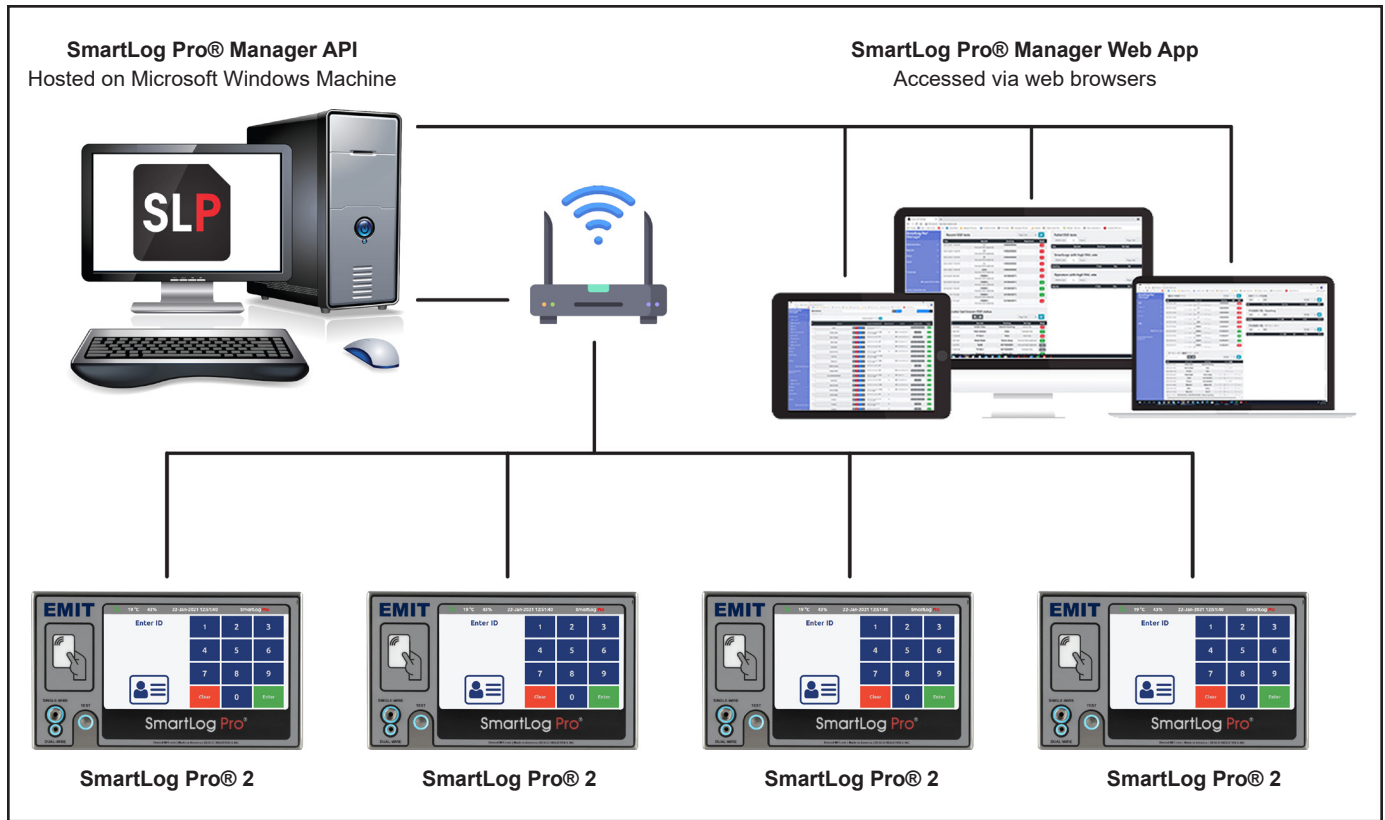

Figure 2. SmartLog Pro® Manager system overview

Items and Accessories

Item	Description
50172	SmartLog Pro® Manager Web App
50177	Facial Recognition Terminal
50180	SmartLog Pro® 2, with North America Power Cord
50181	SmartLog Pro® 2, without Power Cord
50182	Alvarado EDC Turnstile, 120VAC
50183	Retrofit Turnstile Bracket
50184	Replacement Dual-Wire Wrist Strap Jack
50185	Replacement Dual Foot Plate
50186	Replacement Foot Plate Cable
50187	Replacement Power Adapter
50417	Stand
50424	Limit Comparator for Testers
50755	ESD Glove Test Fixture
50756	Contactless Test Switch
50783	Turnstile Mounting Kit
50784	5-Pound Electrode for Limit Comparator
50788	Handheld QR Code Scanner, USB

Packaging

- 1 SmartLog Pro® 2
- 1 Wall Bracket
- 1 Dual Foot Plate
- 1 Power Adapter
- 1 Power Cord with North America Plug (50180 only)
- 1 Foot Plate Cable
- 1 Micro USB Cable
- 1 Ground Cord
- 1 Thumb Screw
- 2 Mounting Anchors
- 2 Mounting Screws
- 2 Zip Ties
- 1 Plunger and Spring Assembly for 10 mm Wrist Cord Adapter (50181 only)



Figure 3. EMIT 50180 SmartLog Pro® 2 packaging contents

Features and Components

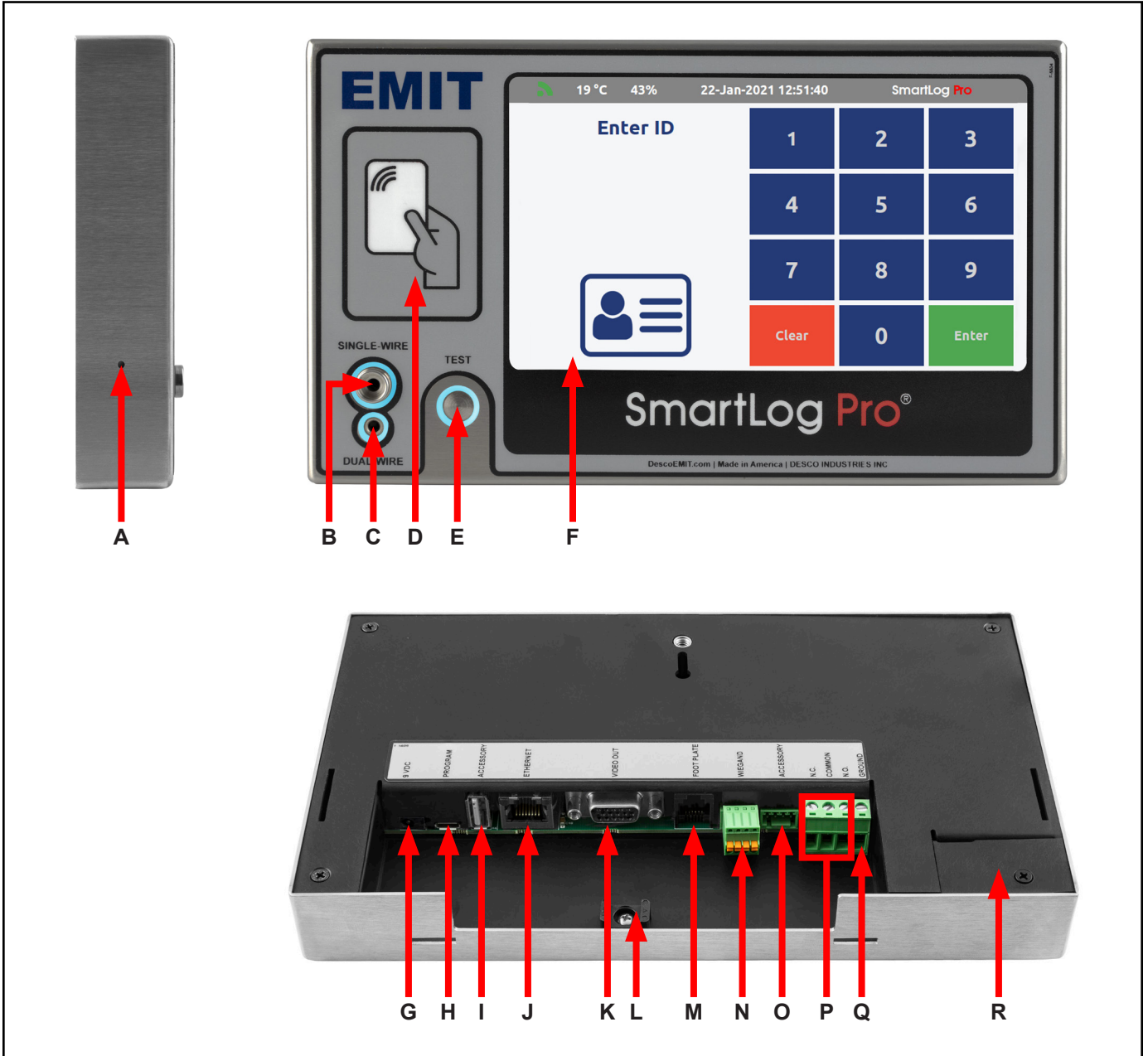

Figure 4. SmartLog Pro® 2 features and components

A. Reset Switch: Resets the SmartLog Pro® 2.

B. Single-Wire Wrist Strap Jack: Connect the single-wire wrist cord here to test its wrist strap. See “10 mm Wrist Cord Adapter” on page 8 if using single-wire wrist cords with a 10 mm snap termination.

C. Dual-Wire Wrist Strap Jack: Connect the dual-wire wrist cord here to test its wrist strap.

D. Embedded Dual Frequency Proximity Reader: Reads proximity cards and initiates the test prompt.

E. Solid-State Test Switch: Initiates the test sequence when a finger is placed onto it.

F. Touchscreen Display: Displays the keypad, time, date, temperature, humidity, command prompts, test results, and settings.

G. 9 VDC Power Jack: Accepts the 9 VDC power adapter supplied with the SmartLog Pro® 2.

H. Proximity Reader Configuration Port: Accepts the micro USB cable supplied with the SmartLog Pro® 2 to configure the embedded proximity reader. See “Configuring the Proximity Reader” on page 6 for more information.

I. USB Accessory Port: Accepts EMIT certified external readers and accessories.

J. Ethernet Jack: Accepts Ethernet cables and provides network communication between the SmartLog Pro® 2 and SmartLog Pro® Manager.

K. VGA Port: Outputs a mirrored image of the tester’s display to an external monitor. The native video resolution is 800 x 480.

L. Cable Tie Mount: Secures the cables and cords connected to the SmartLog Pro® 2 with the included zip ties

M. Foot Plate Jack: Accepts the foot plate cable connected to the dual foot plate.

N. Wiegand Terminal: Accepts Wiegand input from external readers. See “Wiegand Terminal” on page 9 for more information.

O. External Test Switch Port: Accepts input from the EMIT 50755 ESD Glove Test Fixture and 50756 Contactless Test Switch.

P. Relay Terminal: Integrates with electronic door locks, lights, buzzers, etc. See “Relay Terminal” on page 9 for more information.

Q. Ground Terminal: Bonds the tester’s enclosure to equipment ground. This connection is optional as the test circuit is grounded via the power adapter.

R. Dual-Wire Jack Access Port: Provides access to the dual-wire wrist strap jack when a replacement is needed. See “Replacing the Dual-Wire Wrist Strap Jack” on page 13 for more information.

Installation

Configuring the Proximity Reader

The SmartLog Pro® 2 contains an rf IDEAS WAVE ID® Plus reader capable of reading virtually any proximity or contactless card type in the world. The dual-frequency reader has the ability to hold four user-defined ID card configurations. Use the procedure below to configure the reader at a PC workstation prior to dispatching the SmartLog Pro® 2 for use.

1. Visit the rf IDEAS software downloads website.
<https://www.rfideas.com/support/tools/downloads>
2. Download and install the **rf IDEAS Configuration Utility** app for Windows.
3. Connect the SmartLog to power, and wait for it to boot-up.
4. Access the Admin Menu by entering an administrator ID number on the keypad. The default administrator ID number is 0.
5. Tap the General button. NOTE: The SmartLog must remain in the General Menu for the remainder of this procedure.

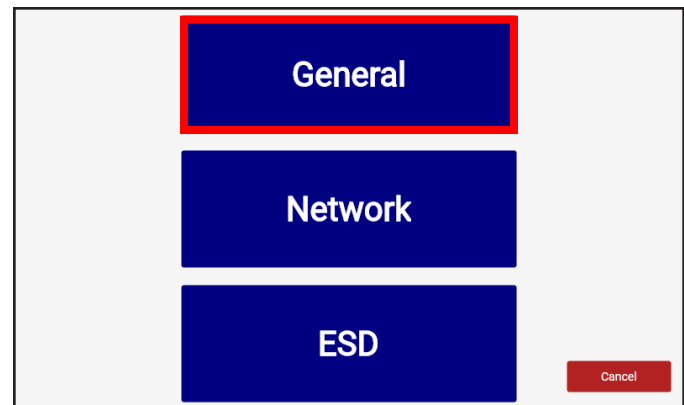

Figure 5. Locating the General button in the Admin Menu

6. Connect the included micro USB cord to the SmartLog. Connect the opposite end of the cord to a Windows PC. Windows will install the reader’s driver.
7. Open the rf IDEAS Configuration Utility app.
8. Click the link below to view the Configuration Utility User Manual, and follow the Card Analyzer procedure. The Card Analyzer will learn the given proximity cards and configure the reader accordingly.
https://www.rfideas.com/sites/default/files/2021-08/rfIDEAS_Configuration_UTILITY_User_Manual_0.pdf
9. Disconnect the micro USB cable from the SmartLog after the Card Analyzer procedure is completed.

- Exit the General Menu on the SmartLog and return to the home screen.
- Present a proximity card to the SmartLog. Confirm that the SmartLog recognizes the ID card and prompts for a test to be performed.

Cloning the Proximity Reader

The cloning feature clones the settings of a configured reader to other readers. Follow the procedure below if more than one SmartLog Pro® 2 will be installed at the facility.

- Access the Admin Menu by entering an administrator ID number on the keypad. The default administrator ID number is 0.
- Tap the General button. NOTE: The SmartLog must remain in the General Menu for the remainder of this procedure.

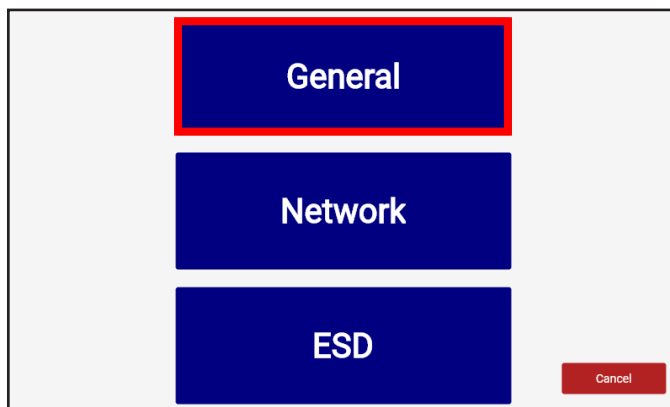

Figure 6. Locating the General button in the Admin Menu

- Connect the included micro USB cord to the SmartLog. Connect the opposite end of the cord to a Windows PC.
- Open the rf IDEAS Configuration Utility app.
- Click the link below to view the Configuration Utility User Manual, and follow the Cloning procedure.
https://www.rfideas.com/sites/default/files/2021-08/rfIDEAS_Configuration_UTILITY_User_Manual_0.pdf
- Disconnect the micro USB cable from the SmartLog after the cloning procedure is completed.
- Exit the General Menu on the SmartLog and return to the home screen.
- Present a proximity card to the SmartLog. Confirm that the SmartLog recognizes the ID card and prompts for a test to be performed.

Hardware Setup

If the SmartLog Pro® 2 is located near a restroom, sink or other water source, operators will need to be instructed to thoroughly dry their hands before testing. Wet hands may cause inaccurate test results and damage to the tester.

- Connect the foot plate cable, power adapter, ground cord (optional) and Ethernet cable (optional) to the SmartLog.
- Route all cables through the U-shaped opening located at the bottom of the SmartLog and secure them to the cable tie mount with a zip tie.
- Connect the ground cord's ring terminal to a known ground point. Connect the foot plate cable to the foot plate. If using an Ethernet cable, verify that it is connected to the network.
- Power the SmartLog by connecting its power adapter to an appropriate power receptacle. The display will turn on, and the boot sequence will initiate. "Scan or Enter ID" will display on the SmartLog after the boot sequence has completed. The blue LEDs will continuously cycle around the test switch when the ESD tester is on standby.
- Use the included screws and anchors to secure the mounting bracket to the desired location. The screws may be used in any of the four holes shown below. Be sure to locate the bracket where operators can read the display and use the tester.

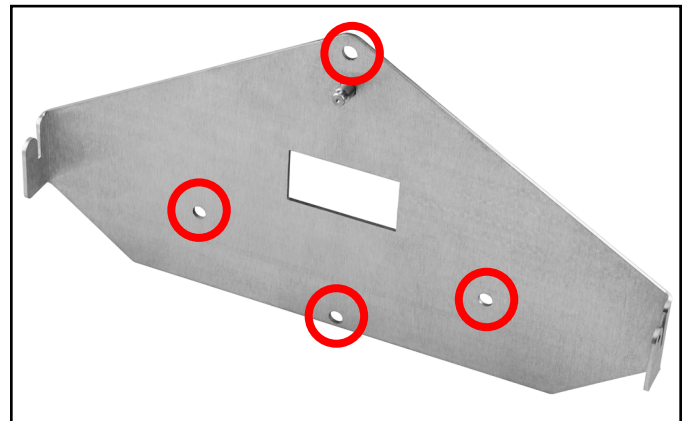

Figure 7. Mounting holes on the SmartLog Pro® 2 mounting bracket

- Connect the SmartLog to the bracket. Use the included thumbscrew to secure the SmartLog as shown below.

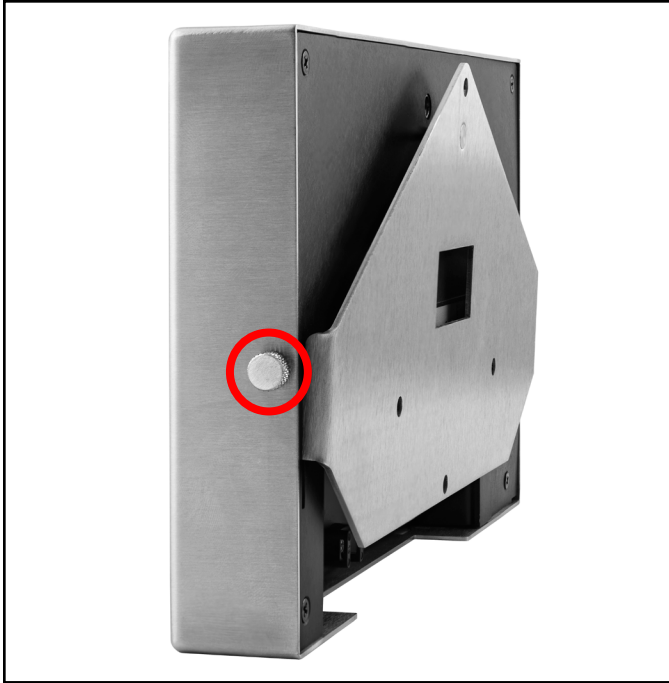

Figure 8. Securing the SmartLog Pro® 2 to the mounting bracket



Figure 9. Using the EMIT 50417 SmartLog Stand as a mounting alternative

10 mm Wrist Cord Adapter

A plunger and spring assembly is included with the 50181 SmartLog Pro® 2. Use this assembly to convert the single-wire jack on the SmartLog Pro® 2 to test wrist cords with a 10 mm termination instead of a banana plug. NOTE: This assembly cannot be removed once installed.

1. Insert the plunger assembly into the single-wire jack on the face of the SmartLog. Be sure to clear the clip at the base of the plunger's shaft when inserting into the jack.



Figure 10. Inserting the plunger and spring assembly into the single-wire jack

2. The plunger will slightly protrude out of the single-wire jack when installed. Test its installation by pushing down on the plunger. It should dip and then spring back up when released.



Figure 11. Completed installation of the plunger and spring assembly

Relay Terminal

The SmartLog Pro® 2 features a relay terminal that can be integrated with electronic door locks, lights, buzzers, etc. to control access to an area. The relay open and close (activation) time may be modified using the SmartLog Pro® Manager Web App.

Contact Rating	1A @ 30VDC, .5A @ 125VAC
Maximum Switching Power	30W
Maximum Switching Voltage	250VAC, 220VDC
Maximum Switching Current	1A

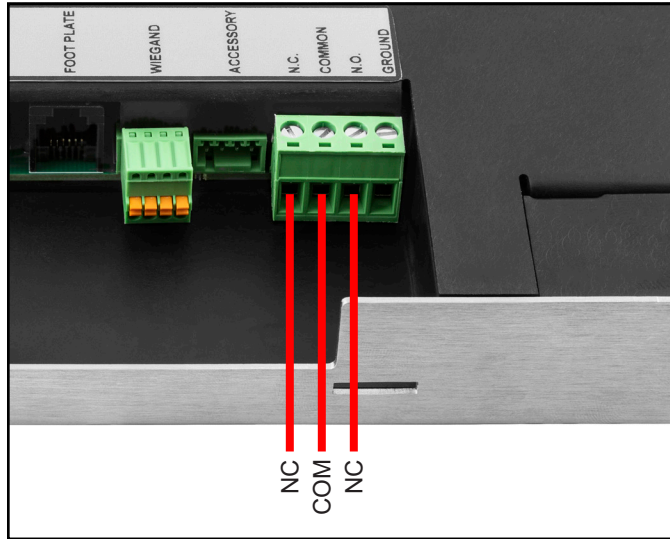

Figure 12. Relay terminal contacts located on the back of the SmartLog Pro® 2

Wiegand Terminal

The SmartLog Pro® 2 features a terminal that can be paired with external Weigand interface devices to enter Test IDs.

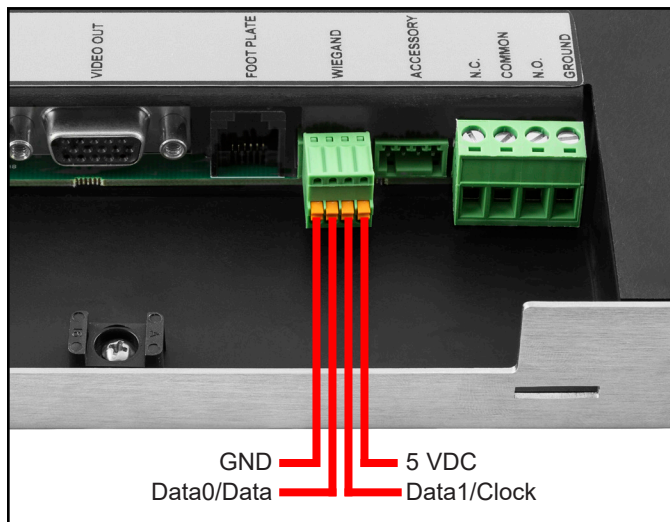

Figure 13. Wiegand terminal contacts located on the back of the SmartLog Pro® 2

Wi-Fi Setup

Use the Wi-Fi setup to wirelessly connect the SmartLog Pro® 2 to the network in instances where Ethernet cable is not used.

1. Access the Admin Menu by entering an administrator ID number on the keypad. The default administrator ID number is 0. Use SmartLog Pro® Manager to change the ID number if desired.
2. Tap the Network button.

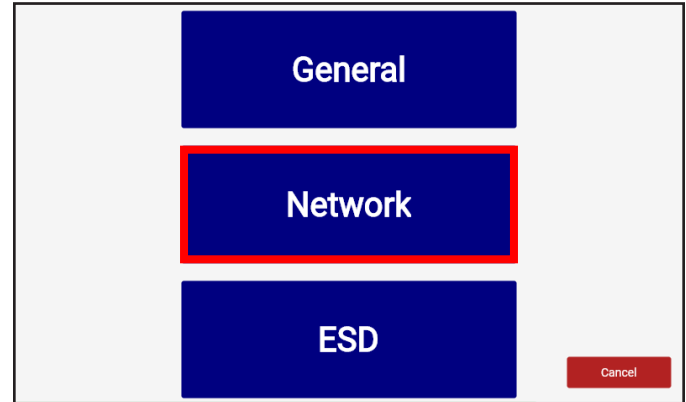

Figure 14. Locating the Network button in the Admin Menu

3. Toggle the Enable WiFi button in the bottom left corner, and select a wireless network from the table above. Enter a password to join the wireless network if prompted.

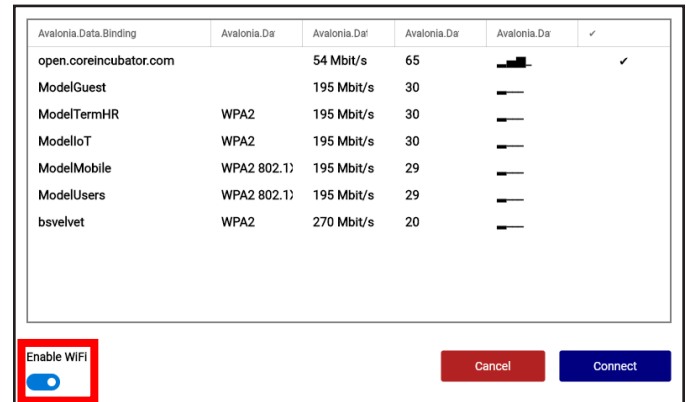

Figure 15. Enabling Wi-Fi

Language Selection

1. Access the Admin Menu by entering an administrator ID number on the keypad. The default administrator ID number is 0. Use SmartLog Pro® Manager to change the ID number if desired.
2. Tap the General button.

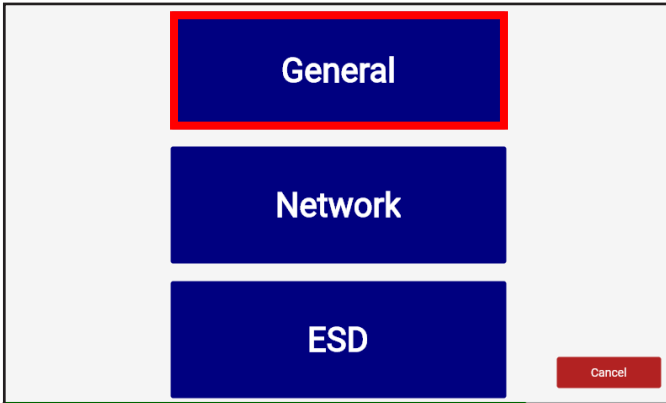

Figure 16. Locating the General button in the Admin Menu

3. Select one of the Language options listed at the top of the page. Tap the Save button when complete.



Figure 17. Selecting a language setting

Sync Internet Time

The SmartLog Pro® 2 can automatically set the time and date based on the location of its installation. NOTE: The SmartLog must be on a LAN and have outside internet access to WorldTimeAPI.org to use this feature.

1. Access the Admin Menu by entering an administrator ID number on the keypad. The default administrator ID number is 0. Use SmartLog Pro® Manager to change the ID number if desired.
2. Tap the General button.

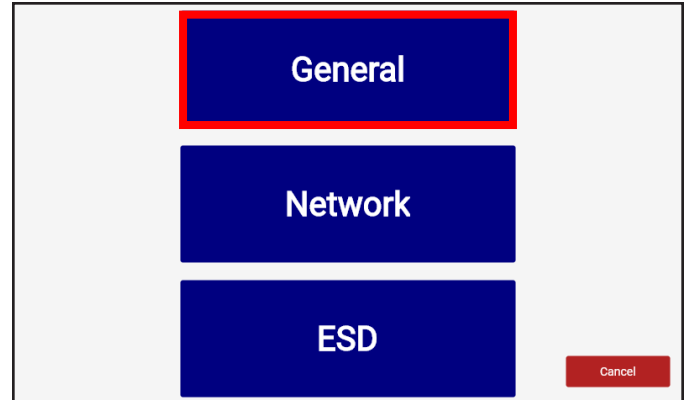

Figure 18. Locating the General button in the Admin Menu

3. Scroll to the bottom of the page. Tap the Sync Internet Time checkbox to enable the feature. Tap the Save button when complete.

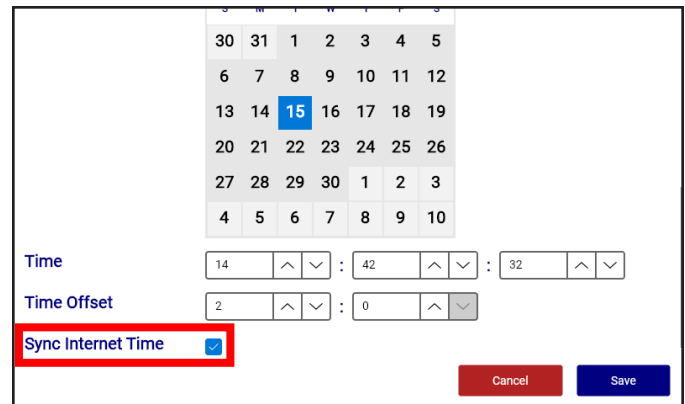

Figure 19. Enabling the Sync Internet Time feature

Test Limit Configuration

The footwear and wrist strap resistance limits listed below are available in the SmartLog Pro® 2. The default test limits are highlighted in green.

Wrist Strap	
Low Limit	High Limit
100 kilohms (1.0×10^5)	10 megohms (1.0×10^7)
750 kilohms (7.5×10^5)	35 megohms (3.5×10^7)
Footwear	
Low Limit	High Limit
100 kilohms (1.0×10^5)	10 megohms (1.0×10^7)
750 kilohms (7.5×10^5)	35 megohms (3.5×10^7)
	100 megohms (1.0×10^8)
	1 gigohm (1.0×10^9)**

**A dirty foot plate could result in a false test result when using this test limit. Keep the foot plate clean by using 99% isopropyl alcohol. This test limit is not recommended in environments with a relative humidity greater than 50%.

1. Access the Admin Menu by entering an administrator ID number on the keypad. The default administrator ID number is 0. Use SmartLog Pro® Manager to change the ID number if desired.
2. Tap the ESD button.

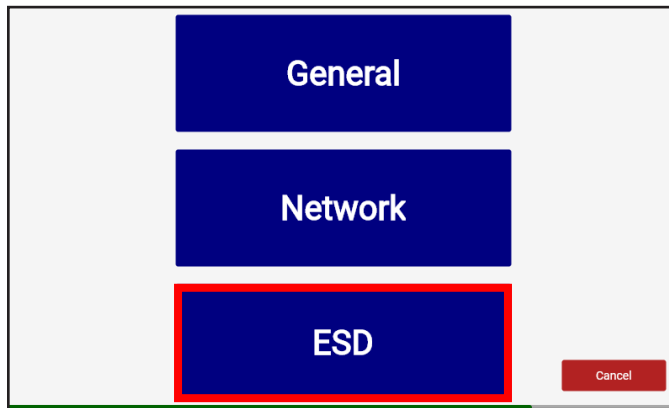

Figure 20. Locating the ESD button in the Admin Menu

3. Select the desired Default Test at the top of the page. Select the desired Wrist Strap and Footwear test limits at the bottom of the page. Tap the Save button when complete.

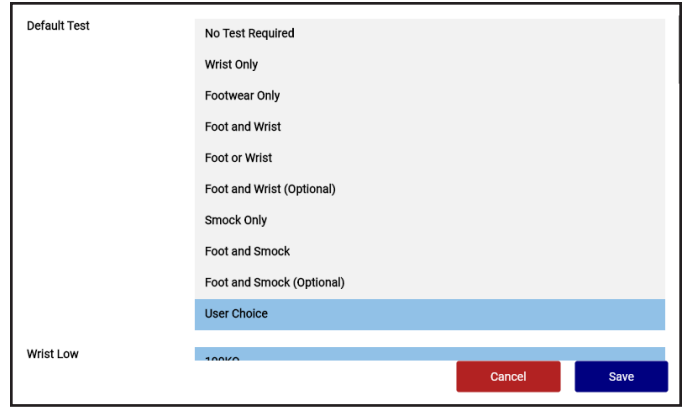

Figure 21. Selecting the default test

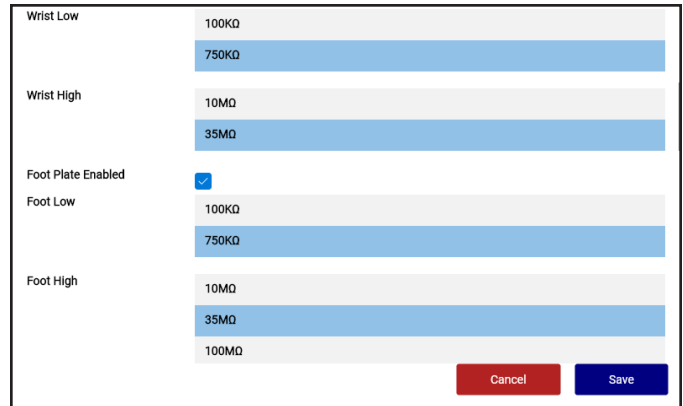

Figure 22. Selecting the test limits

Operation

NOTE: The SmartLog Pro® 2 must first be programmed with the user ID table using the SmartLog Pro® Manager Web App before being deployed for employee use, or the default test settings will be applied.

See technical bulletin [TB-6605](#) for more information.

If the SmartLog Pro® 2 is located near a restroom, sink or other water source, operators should be instructed to thoroughly dry their hands before testing. Wet hands may cause inaccurate test results and damage to the tester.

1. A circling light around the test switch indicates when the SmartLog is on standby and ready to perform a test.
2. Initiate the test procedure by entering a test ID number into the SmartLog. This may be done using the touchscreen keypad or proximity reader.

NOTE: Hold the proximity card in front of the RFID icon for a full second if using proximity cards.



Figure 23. Entering a test ID number using the touchscreen keypad



Figure 24. Holding a proximity badge in front of the RFID icon on the SmartLog Pro® 2

3. Follow the prompt on the SmartLog's display.
4. When performing a footwear test, be sure to place both feet on the dual foot plate (one foot per plate).

NOTE: Keep the foot plate clean with 99% isopropyl alcohol when using the 1 Gigohm high test limit. A dirty foot plate could yield a false pass.

When performing a wrist strap* test, be sure to completely plug in the wrist cord into the tester's jack.

5. To begin the test, use a finger to bridge the test switch's inner and outer contacts. The blue standby LED will become solid to indicate that the test has been initiated. Hold the finger down until the test results are displayed on the touchscreen.

If the finger is removed too early, the tester's blue LEDs will blink three times to indicate that the test was not completed. DO NOT touch any other metal while performing the test as this will affect the results.

6. The relay terminal will activate if the defined tests are passed (if applicable).

NOTE: Failures may be caused by dry skin or minimal sweat layer. For wrist straps, try using an approved dissipative hand lotion such as [Menda Reztore® ESD Hand Lotion](#) prior to use. Footwear test results can be improved by taking a short walk to build a sweat layer for better conductivity.

*The SmartLog Pro® 2 may also be used to test smocks or garments that feature a grounding mechanism for operators using a coiled cord connection.



Figure 25. Performing a single-wire wrist strap test

Maintenance

To maintain optimum performance, cleaning should be performed on a regular basis. Use 99% isopropyl alcohol to clean the foot plate and test switch. Other cleaners are susceptible to leaving residue on these surfaces. NOTE: Avoid wetting or mopping the foot plate. This may yield false test results and cause damage to its internal circuitry.

Replacing the Dual-Wire Wrist Strap Jack

The dual-wire wrist strap jack inside the SmartLog Pro® 2 can be replaced if it begins to show wear and tear damage. The replacement dual-wire wrist strap jack is available as item 50184.

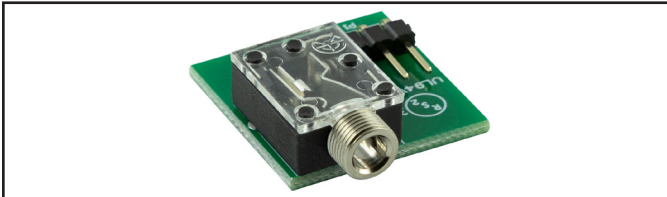

Figure 26. EMIT 50184 Replacement Dual-Wire Wrist Strap Jack

1. Locate the access port on the backside of the SmartLog and remove the flathead screw.

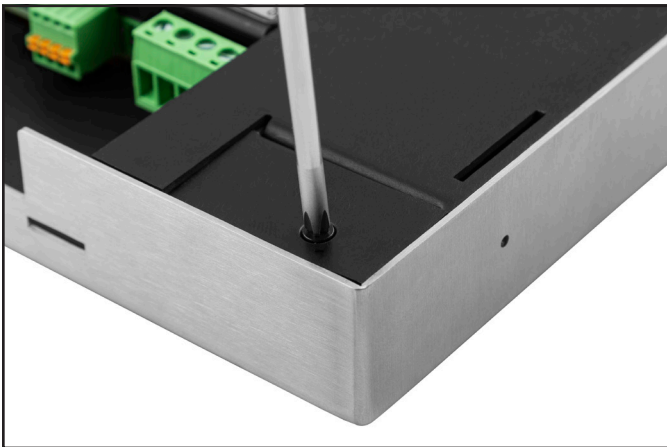

Figure 27. Removing the screw from the access cover

2. Use a small hand tool to pry the access cover open.



Figure 28. Opening the access cover

3. Insert a small hand tool into the circular hole located on the dual-wire jack PCB, and use it to lift the PCB from the SmartLog. Discard the used PCB.



Figure 29. Lifting the used dual-wire wrist strap jack from the SmartLog

4. Install the replacement PCB into the SmartLog.

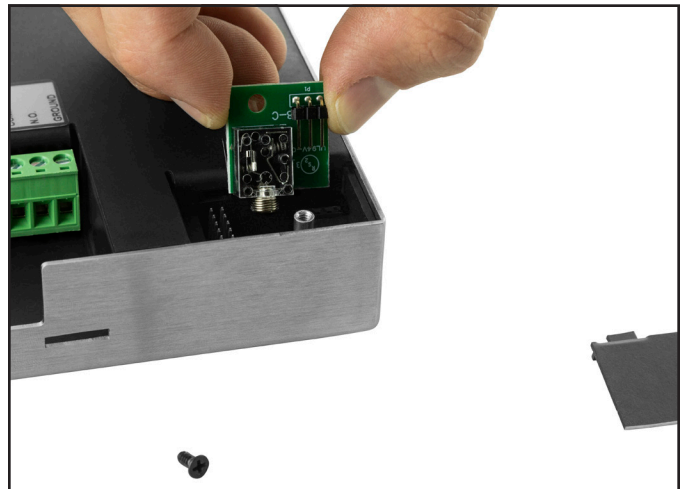

Figure 30. Installing the replacement dual-wire wrist strap jack

5. Close the access cover and reinstall the screw.
6. Perform a dual-wire wrist strap test to confirm a successful installation.

Calibration

Frequency of recalibration should be based on the critical nature of those ESD sensitive items handled and the risk of failure for the ESD protective equipment and materials. In general, EMIT recommends that calibration be performed annually.

Use the EMIT 50424 Limit Comparator and EMIT 50784 5-Pound Electrode to perform periodic verification (once every 6-12 months) of the SmartLog Pro® 2. The Limit Comparator can be used to check the test limits of the SmartLog Pro® 2 without removing it from the factory floor.

See technical bulletin [TB-6581](#) for more information.

NOTE: Calibration is not required for the temperature and humidity sensor embedded within the SmartLog Pro® 2.



Figure 31. EMIT 50424 Limit Comparator



Figure 32. EMIT 50784 5-Pound Electrode for Limit Comparator

Specifications

SmartLog Pro® 2

Input Voltage and Frequency (External Adapter)	Power Input: 100-240 VAC, 50/60 Hz
	Power Output: 9.0 VDC, 3.0 A
	Power Adapter Cable Length: 5.0' (1.5 m)
	Power Cord Length: 7.5' (2.3 m)

Operating Temperature	70° to 85° F (21° to 30° C) for 1 gigohm test limit 41° to 85° F (5° to 30° C) for all other test limits
-----------------------	---

Dimensions	5.3" x 9.0" x 1.1" (135 x 229 x 28 mm)
------------	---

Weight	1.7 lbs (0.8 kg)
--------	------------------

Test Accuracy	±20% for 1 gigohm footwear test limit; ±10% for all other test limits
---------------	---

Test Switch Voltage	5 VDC @ open circuit
---------------------	----------------------

Wrist Strap and Footwear Test Voltage	30 VDC @ open circuit; Test current is limited by resistors and varies on the test range setting (100 kilohms - 1 gigohm)
---------------------------------------	---

Temperature Accuracy	±0.5° C
----------------------	---------

Humidity Accuracy	±5%
-------------------	-----

Available Languages	English, Spanish, Japanese, Chinese (Simplified), Turkish, Thai, French
---------------------	---

Proximity Reader Supported Card Types	Click here
---------------------------------------	----------------------------

Ethernet Transceiver	Microchip KSZ8041
----------------------	-------------------

Wi-Fi Module	AzureWave AW-CM276NF
--------------	----------------------

Country of Origin	United States of America
-------------------	--------------------------

Dual Foot Plate

Dimensions	13.25" x 15.25" x 1.125" (337 mm x 387 mm x 29 mm)
------------	---

Weight	5.5 lbs (2.5 kg)
--------	------------------

Cable Length	7.0' (2.1 m)
--------------	--------------

Country of Origin	United States of America
-------------------	--------------------------

Limited Warranty, Warranty Exclusions, Limit of Liability and RMA Request Instructions
 See the EMIT Warranty - DescoEMIT.com/Warranty.aspx